



# POWER CAPACITORS

HDMKP



## Capacitors for Power Electronics

### KEY BENEFITS

- High RMS current rating: up to 150 A
- High impulse current rating: up to 25 kA
- Low self-inductance of 70 nH
- High reliability and life expectancy
- Withstands heavy-duty shock and vibration
- Non-polar dielectric

### APPLICATIONS

- DC-linking and DC filtering in industry and traction converters
- DC-linking in low-power drives
- DC-linking in wind turbine converters
- Impulse discharge capacitors for magnetizing and welding
- Replacement of aluminum electrolytic capacitors (lower capacitance, higher currents)
- AC filter in UPS

# Capacitor Power Electronics

## FEATURES

- High RMS current rating: up to 150 A
- High impulse current rating: up to 25 kA
- Low self-inductance of 70 nH
- High reliability and life expectancy
- Withstands heavy-duty shock and vibration
- Non-polar dielectric

## APPLICATIONS

- DC-linking and DC-filtering in industry and traction converters
- DC-linking in low - power drives
- DC-linking in windturbine converters
- Impulse discharge capacitors for magnetizing and welding
- Replacement of aluminum electrolytic capacitors (lower capacitance, higher currents)
- AC filter in UPS



## QUICK REFERENCE DATA

DESCRIPTION	VALUE
Dielectric	Metallized polypropylene
Dissipation factor (tan δ)	< 2 x 10 <sup>-4</sup> /1 kHz
Capacitance tolerance	± 5 %
Operating temperature (hot spot)	θ <sub>min.</sub> - 40 °C θ <sub>max.</sub> + 80 °C
Inductance	70 nH
Lifetime expectancy	100 000 h at U <sub>R</sub> and < 70 °C hotspot
Reliability	100 FIT
Test voltage	Terminal/terminal = 1.5 x U <sub>DC</sub> ; 10 s terminal/case = 2 x U <sub>DC</sub> + 1000 V <sub>AC</sub> ; 60 s
Casing material	Aluminum/Bergand 3700 UF
Filling	Resin dry, UL 94 V-0
Standards	IEC 61071-1, IEC 61881 and EN 61071-1

## DIMENSIONS

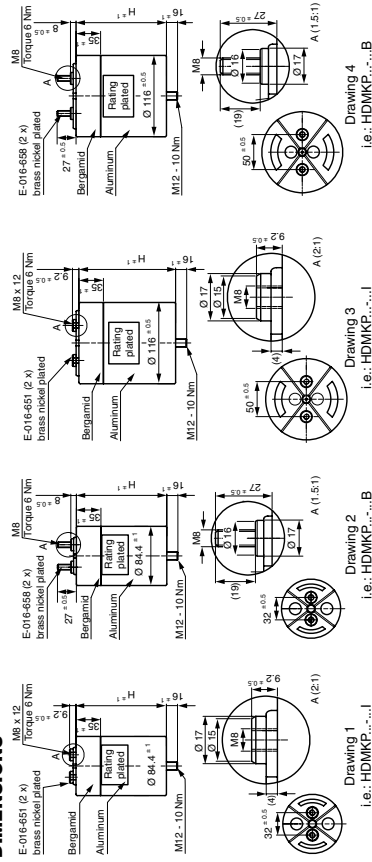

Drawing 1 i.e.: HDMKP...-1  
Drawing 2 i.e.: HDMKP...-2  
Drawing 3 i.e.: HDMKP...-3  
Drawing 4 i.e.: HDMKP...-4

HDMKP 900, U <sub>DC</sub> = 900 V, U <sub>N</sub> = 220 V <sub>RMS</sub>												
TYPE	C <sub>0</sub> [μF]	V <sub>OC</sub>	R <sub>s</sub> [mΩ]	R <sub>th</sub> [K/W]	I <sub>max</sub> [A]	I <sub>p</sub> [A]	I [A]	HEIGHT [mm]	DIA. [mm]	WEIGHT [kg]	PACKAGING UNIT	DRAWING NO.
900-360	360	900	2.4	6.0	32.0	1309	3928	105	84.4	0.7	4	1 and 2
900-460	460	900	3.2	5.4	29.0	1258	3775	135	84.4	0.9	4	1 and 2
900-720	720	900	1.3	3.2	59.0	1329	3988	185	84.4	1.2	4	1 and 2
900-950	950	900	1.7	2.7	56.0	1300	3989	235	84.4	1.6	4	1 and 2
900-1080	1080	900	0.9	2.2	85.0	1316	3948	260	84.4	1.7	4	1 and 2
900-2050	2050	900	1.3	1.7	75.0	5610	16 830	235	116	3.0	4	3 and 4
900-2235	2235	900	0.6	1.6	120.0	8385	25 155	260	116	3.3	4	3 and 4
HDMKP 1.1, U <sub>DC</sub> = 1100 V, U <sub>N</sub> = 275 V <sub>RMS</sub>												
1.1-240	240	1100	2.9	4.1	28.0	1125	3375	105	84.4	0.7	4	1 and 2
1.1-325	325	1100	3.8	4.8	27.0	1112	3335	135	84.4	0.9	4	1 and 2
1.1-480	480	1100	1.6	2.5	50.0	2250	6750	185	84.4	1.2	4	1 and 2
1.1-650	650	1100	0.8	2.7	50.0	2220	6660	235	84.4	1.6	4	1 and 2
1.1-720	720	1100	0.5	2.2	75.0	3375	10 125	260	84.4	1.7	4	1 and 2
1.1-1310	1310	1100	1.5	1.8	72.0	4485	13 455	235	116	3.0	4	3 and 4
1.1-1425	1425	1100	0.6	1.7	114.0	6680	20 045	260	116	3.3	4	3 and 4
HDMKP 1.35, U <sub>DC</sub> = 1350 V, U <sub>N</sub> = 325 V <sub>RMS</sub>												
1.35-160	160	1350	3.2	6.7	26.0	900	2699	105	84.4	0.7	4	1 and 2
1.35-200	200	1350	4.2	4.6	51.0	893	2660	135	84.4	0.9	4	1 and 2
1.35-320	320	1350	1.7	3.5	50.0	900	2699	185	84.4	1.2	4	1 and 2
1.35-400	400	1350	2.4	3.1	45.0	820	2460	235	84.4	1.6	4	1 and 2
1.35-480	480	1350	1.2	2.4	72.0	900	2699	260	84.4	1.7	4	1 and 2
1.35-910	910	1350	1.6	1.9	70.0	3735	11 205	235	116	3.0	4	3 and 4
1.35-990	990	1350	0.7	1.8	108.0	5565	16 695	260	116	3.3	4	3 and 4
HDMKP 2.0, U <sub>DC</sub> = 2000 V, U <sub>N</sub> = 500 V <sub>RMS</sub>												
2.0-70	70	2000	4.4	7.2	21.0	593	1778	105	84.4	0.7	4	1 and 2
2.0-90	90	2000	5.8	5.9	20.0	585	1755	135	84.4	0.9	4	1 and 2
2.0-140	140	2000	2.3	3.8	41.0	593	1778	185	84.4	1.3	4	1 and 2
2.0-180	180	2000	3.0	3.1	39.0	586	1757	235	84.4	1.6	4	1 and 2
2.0-210	210	2000	1.6	2.7	60.0	593	1760	260	84.4	1.7	4	1 and 2
2.0-300	300	2000	2.0	2.1	60.0	2455	7365	235	116	3.0	4	3 and 4
2.0-420	420	2000	0.9	1.9	90.0	3650	10 955	260	116	3.3	4	3 and 4
HDMKP 2.25, U <sub>DC</sub> = 2250 V, U <sub>N</sub> = 550 V <sub>RMS</sub>												
2.25-55	55	2250	4.8	7.4	20.0	530	1590	105	84.4	0.7	4	1 and 2
2.25-75	75	2250	6.4	6.0	19.0	523	1568	135	84.4	0.9	4	1 and 2
2.25-110	110	2250	2.5	3.9	39.0	530	1590	185	84.4	1.2	4	1 and 2
2.25-150	150	2250	3.3	3.2	37.0	523	1568	235	84.4	1.6	4	1 and 2
2.25-165	165	2250	1.7	2.7	56.0	530	1590	260	84.4	1.7	4	1 and 2
2.25-320	320	2250	2.4	2.4	56.0	2235	6705	235	116	3.0	4	3 and 4
2.25-345	345	2250	1.1	2.0	90.0	3330	9990	260	116	3.3	4	3 and 4
HDMKP 2.7, U <sub>DC</sub> = 2700 V, U <sub>N</sub> = 660 V <sub>RMS</sub>												
2.7-40	40	2700	5.1	8.4	18.0	464	1391	105	84.4	0.7	4	1 and 2
2.7-50	50	2700	7.4	6.5	17.0	419	1258	135	84.4	0.9	4	1 and 2
2.7-80	80	2700	5.1	6.8	20.0	464	1391	185	84.4	1.2	4	1 and 2
2.7-100	100	2700	7.4	5.3	19.0	419	1258	235	84.4	1.6	4	1 and 2
2.7-120	120	2700	5.2	6.2	21.0	450	1349	260	84.4	1.7	4	1 and 2
2.7-220	220	2700	2.4	2.4	52.0	925	2775	235	116	3.0	4	3 and 4
2.7-240	240	2700	1.1	2.0	84.0	927	2761	260	116	3.3	4	3 and 4

## Note

- Other voltage, current and capacitance values are available on request

Build Vishay into your Design

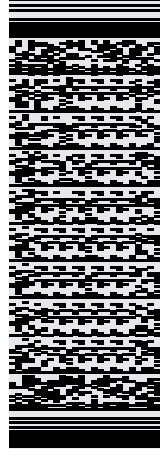

**DISCLAIMER** All product specifications and data are subject to change without notice. Vishay Intertechnology, Inc., its affiliates, agents, and employees, and all persons acting on its or their behalf (collectively, "Vishay"), disclaim any and all liability for any errors, inaccuracies or incompleteness contained herein or in any other disclosure relating to any product. Vishay disclaims any and all liability arising out of the use or application of any product described herein or of any information provided herein to the maximum extent permitted by law. The product specifications do not expand or otherwise modify Vishay's terms and conditions of purchase, including but not limited to the warranty expressed therein, which apply to these products. No license, express or implied, by estoppel or otherwise, to any intellectual property rights is granted by this document or by any conduct of Vishay. The products shown herein are not designed for use in medical, life-saving, or life-sustaining applications unless otherwise expressly indicated. Customers using or selling Vishay products not expressly indicated for use in such applications do so entirely at their own risk and agree to fully indemnify Vishay for any damages arising or resulting from such use or sale. Please contact authorized Vishay personnel to obtain written terms and conditions regarding products designed for such applications. Product names and markings noted herein may be trademarks of their respective owners.

For technical questions, contact [esta@vishay.com](mailto:esta@vishay.com)